

935 SERIES

European Style Wall Heater

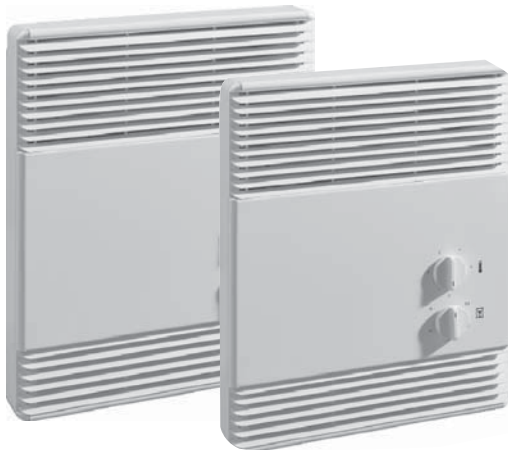

(Shown with optional thermostat & timer)

Applications

- Entryways
- Fire Station Changing Areas
- Offices
- Reception Areas
- Restrooms

The 935 Series wall heater has a stylish, contemporary design with rounded corners and soft lines for an elegant appearance. This heater is ideal for areas with space restrictions and high heating requirements.

- **Unique Element Design:** Stitched ribbon-type heating element provides instant heat for areas that need to be warmed quickly.
- **Three Models:** The standard single-stage heater is controlled by an optional remote line-voltage thermostat. Heater type **T** has a two-stage thermostat which automatically switches from minimum to maximum wattages as needed. Heater type **TZ** is furnished with an additional 0-60 minute mechanical timer that provides manual operation at maximum wattage during occupied periods, then resumes normal two-stage control.
- **Installation Flexibility:** The heater can be recessed in a 2-inch by 3-inch stud wall or surface mounted without the use of adapters.

Standard Construction Features

Heating Elements – Stitched ribbon-type element.

Outlet Grille – The 20-gauge steel grille has a polyester powder paint finish available in white, almond, black or optional stainless steel front cover.

Built-in Controls – Automatic reset thermal cutout prevents overheating.

Fan Motor – Two-speed whisper-quiet squirrel-cage fan operates at 33 dBA with 35 CFM and 42.5 dBA with 70 CFM.

Installation Requirements – The air outlet should be installed a minimum of 12-inches above vinyl floors.

Rough In Dimensions – All heaters: 11-5/8" wide x 15-1/2" high x 2" deep.

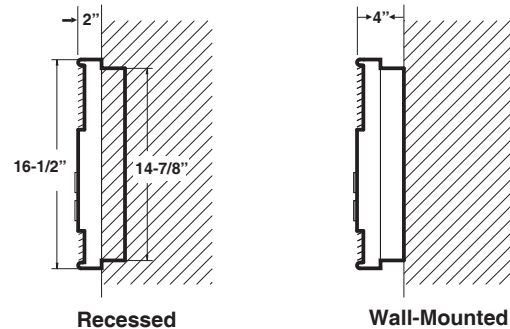
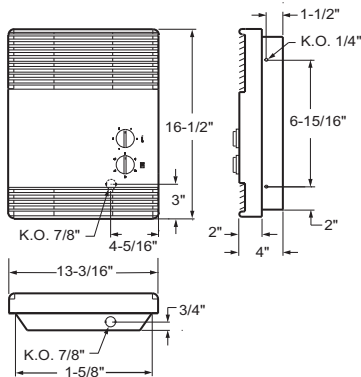

Remote Room Thermostat – See page 99

Heater Listing

Watts		Volts (1 Phase)	Total Amps (1)	CFM		Maximum Air Temperature	Weight lb (kg)	Catalog Number
Minimum	Maximum			Minimum	Maximum			
-	1500	120	13.0	-	70	68 (38)	14 (6)	HX-935U01500B
750	1500	120	13.0	35	70	68 (38)	14 (6)	HX-935U01500B-T
750	1500	120	13.0	35	70	68 (38)	14 (6)	HX-935U01500B-TZ
-	1500/1125	240/208	6.7/5.9	-	70	68/51 (38/28)	14 (6)	HX-935U01500V
750/563	1500/1125	240/208	6.7/5.9	35	70	68/51 (38/28)	14 (6)	HX-935U01500V-T
750/563	1500/1125	240/208	6.7/5.9	35	70	68/51 (38/28)	14 (6)	HX-935U01500V-TZ

(1) Total Amps = Heating element amps and motor amps.

Add **W** to end of catalog number for white finish, **A** for almond, **BK** for black or **SS** for custom stainless steel front cover.

Special or custom colors - See inside back cover for color codes to be added to end of catalog number.