

# Specific Requirements

Straight, Two-Pass and U-Bent elements are furnished with mounting flanges, making them individually removable through the terminal box.

**Safety** – Because the heating coil is completely encased in a grounded metal sheath, shock hazard due to accidental contact with the coil is eliminated. Heaters installed close to a register, grille, or access door should either use finned tubular construction or an open coil unit with a protective screen.

**Airflow Contamination** – If airborne contamination, such as dirt or dust, builds up on open coil elements during shutdown periods, the elements can short out. Finned tubular elements, with their insulated coils, eliminate this problem. Furthermore, upon start-up, a finned tubular heater which has been exposed to droplets of water in the airstream (e.g. immediately downstream from a spray type humidifier, a cooling coil, or a fresh air intake) cannot short to ground as open coils can when support bushings are wet.

**Serviceability** – In the unlikely event of element failure, it is easier to replace individually mounted finned tubular elements than open coil elements.

**Mechanical Stability** – Finned tubular elements are more rugged than open coils. They will withstand more physical abuse.

**Airflow Uniformity** – Finned tubular duct heaters tend to be more tolerant of nonuniform airflow conditions. Heat conducted along the element length reduces or eliminates hot spots resulting from nonuniform airflow. With open coil heaters, it may be necessary to use a pressure plate to compensate for bad airflow conditions.

**Controllability** – Because of their relatively high thermal inertia, finned tubular elements controlled with on/off thermostat systems provide more precise control. Furthermore, finned tubular elements cycle at a reduced rate, thus increasing the life of the power components such as contactors. Nevertheless, when SCR controllers are used, equally precise control can be obtained with either construction.

## Calculating KW Requirements

Once the volume of airflow (CFM – in cubic feet per minute) and the required temperature rise ( $\Delta T$  – in degrees F) through the heater are known, the required kilowatt rating (KW) of the heater can be determined from the formula:

$$KW = \frac{CFM \times \Delta T^{\circ}F}{3193} \quad KW = \left( \frac{\text{Liters/Second} \times \Delta T^{\circ}C}{837} \right)$$

Where the desired heating capacity in BTU/Hr is known, the KW is determined from the following formula:

$$KW = \frac{BTU/Hr}{3412}$$

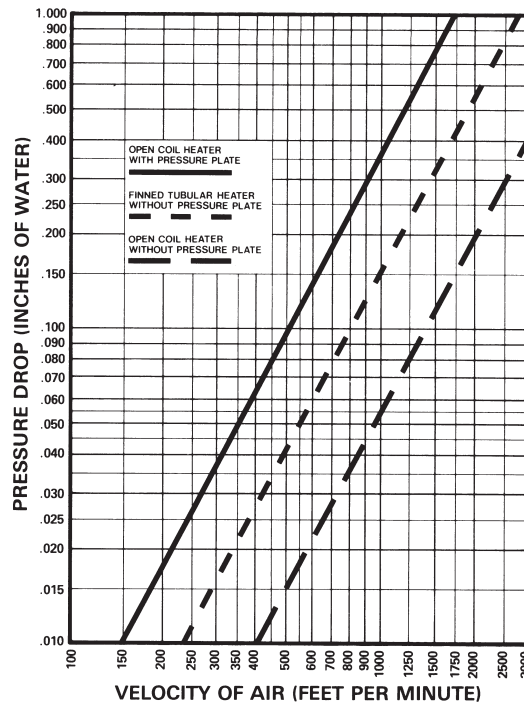

Figure 3.

## Static Pressure Drop

Static pressure drop through an open coil heater is quite low and, in most cases, can be ignored when calculating system pressure drop. The pressure drop across a finned tubular heater is greater than across an open coil. However, if pressure plates must be added to an open coil, the pressure drop over the open coil far exceeds the drop over a finned tubular heater. The curves in Figure 3 give data for all three constructions.



Phone: 314-333-5500  
www.heatrex.com

# Specific Requirements

## Minimum Velocity

Electric heaters differ from steam or hot water coils in that the heat output is constant as long as the heater is energized. Therefore, sufficient airflow must be provided to prevent overheating and nuisance tripping of the thermal cutouts. The minimum required velocity is determined from Figure 4A or 4B on the basis of entering air temperature and KW per square foot of cross sectional duct area.

The maximum air inlet temperature for open coil heaters is 100°F (38°C) and for finned tubular heaters is 80°F (27°C).

Example: Determine whether the minimum air velocity requirement is met for a 10 KW open coil heater installed in a 24" wide x 12" high duct operating with 1000 cubic feet per minute (CFM) of air at a maximum inlet temperature of 65°F:

1. Duct Area = 24" x 12"/144 = 2 sq. ft.
2. KW per square foot = 10 KW/2 sq. ft. = 5.
3. Go to Figure 4B. Use top curve (below 80°F inlet air). Find 5 KW per square foot on the vertical axis. Read minimum velocity required, which in this case is 310 feet per minute (FPM).
4. Heater air velocity = 1000 CFM/2 sq. ft. = 500 FPM. Since 500 FPM exceeds the minimum, this installation is safe. Consult your local HEATREX representative for assistance if you do not have sufficient air velocity.

## Maximum Velocity

High velocity airflow is not normally encountered in typical commercial HVAC applications, when installing open coil duct heaters into velocities over 1200 feet per minute contact your local HEATREX representative.

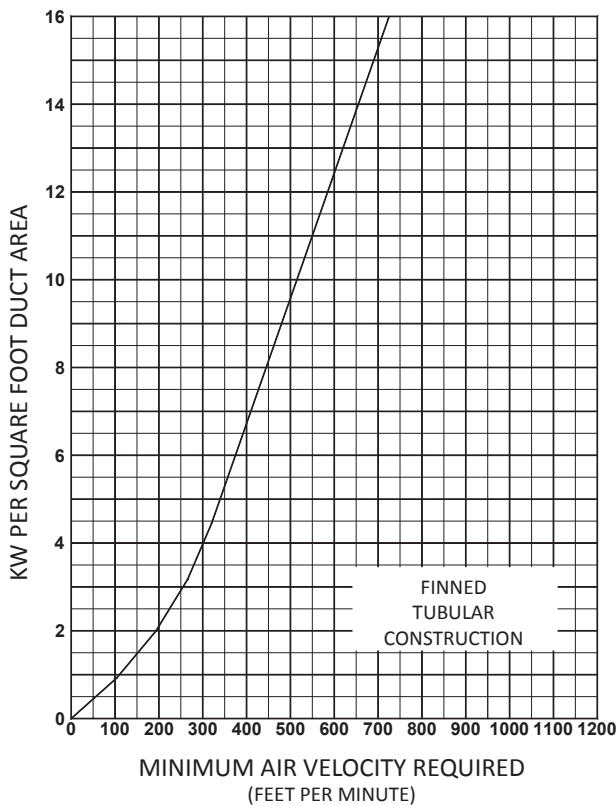

Figure 4A.

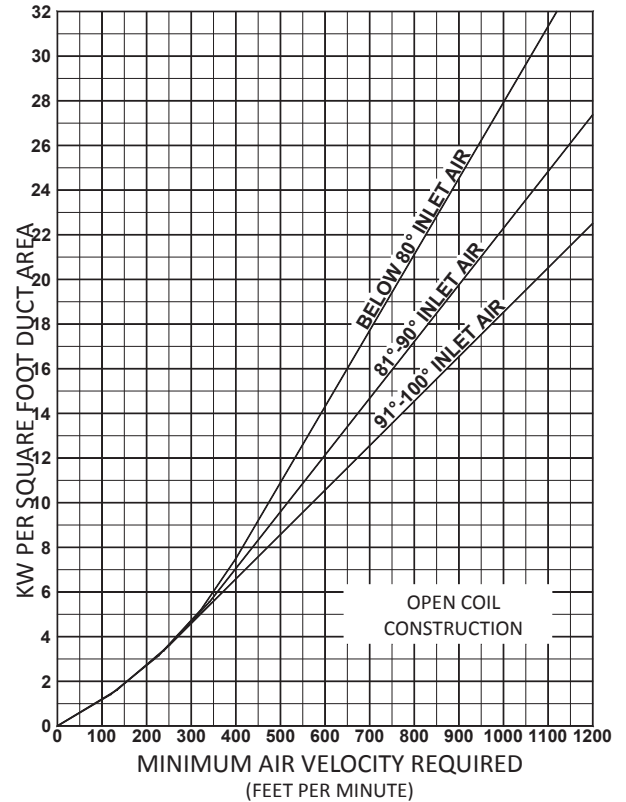

Figure 4B.



## Airflow Uniformity

To prevent hot spots, airflow must be uniformly distributed across the heater face. Figure 5 illustrates typical heater misapplications which result in non-uniform airflow. The heater's UL Listing requires that it not be installed closer than 4' (122 cm) downstream or upstream from a fan outlet, abrupt transition, or other obstructions. Elbows or turns must be located at least 4' (122 cm) from inlet of the heater and 2' (61 cm) from outlet of the heater.

If such an installation cannot be avoided, consult your local HEATREX representative for assistance. We can provide a pressure plate, non-heated zones or special low watt density coils to overcome these problems. Final approval of such applications is up to the local inspection authority.

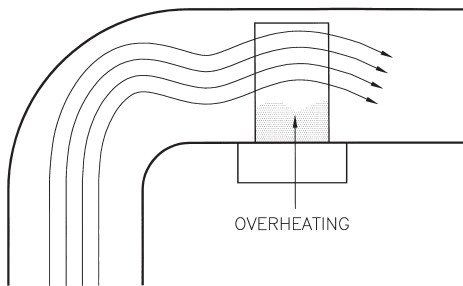

Heater too close to elbow

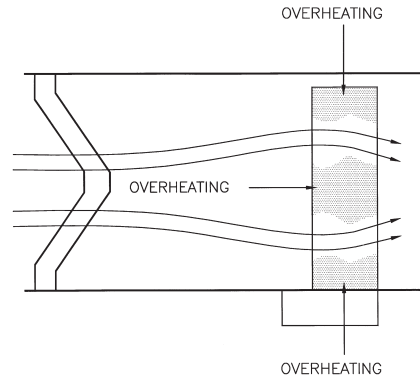

Heater partially blocked by filter or frame member

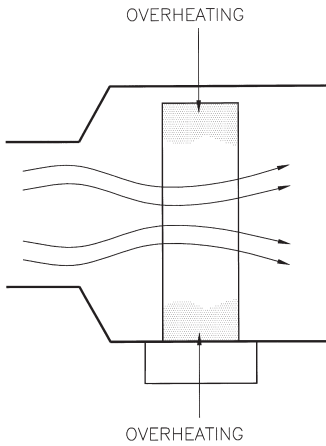

Heater adjacent to transition

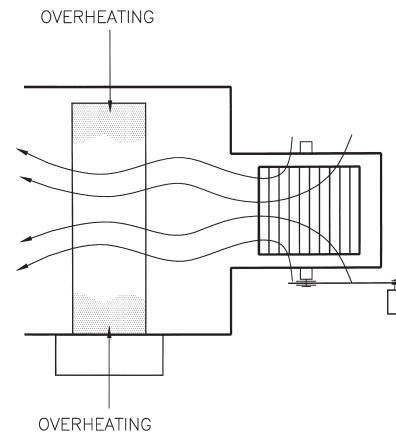

Heater too close to fan

Figure 5.

# Specific Requirements

## Multiple Heaters in the Duct

HEATREX heaters are designed to be used singly, not in series in a duct. Since HEATREX heaters can be furnished in virtually any size and KW rating, series installation of heaters can be avoided.

For very large heaters, field installation and shipping may be simplified by using two or more sections designed for parallel installation, illustrated by Figure 6. Each section, furnished in the flanged design, has individual thermal cutouts. Terminal blocks are provided to interconnect these cutouts in the field. Sections rest stably one on top of the other.

Heaters more than 6' (152 cm) high are normally provided in sections, but larger single section heaters can be provided. Consult your local HEATREX representative for details.

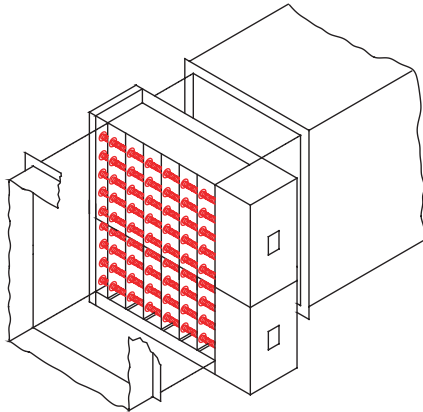

Figure 6.

## Clearance

HEATREX heaters are UL Listed for zero clearance to combustible surfaces. Thus, there is no minimum distance between combustible materials and the section of duct housing the heater, or the heater itself. However, the terminal box must be accessible for servicing. The NEC requires a minimum workspace at least 30" (76 cm) wide by 42" (107 cm) deep for access to the heater terminal box. More space is required for large heaters and for removal of slip-in heaters which are over 42" long.

In addition, sufficient clearance must be provided for convection cooling of all heaters with built-in SCR power controllers (Figure 7). Allow at least 5" (12.7 cm) of free air space around the cooling fins extending from the heater terminal box. Enclosing the fins in any fashion, insulating them, or preventing them from being cooled by normal convection will cause controller failure and void the heater warranty.

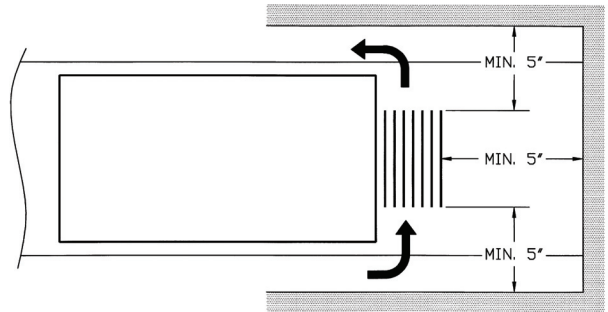

Figure 7.

## UL and NEC Requirements

All HEATREX electric duct heaters described in this catalog meet the requirements of Underwriters Laboratories (UL) and the National Electrical Code (NEC) unless otherwise indicated.†

Heaters furnished with one of the Control Options on pages 10 and 11 are automatically UL Listed and meet NEC requirements. Custom designed heaters must meet certain requirements to comply with UL and the NEC. The areas of particular concern are outlined below.

**Overtemperature Protection** – Duct heaters must be supplied with both primary and secondary overtemperature protection. All HEATREX heaters are provided with both automatic and manual reset thermal cutouts to serve this function.

**Airflow Interlocks** – An airflow interlock must be provided to keep the heater from operating with extremely low or no airflow. HEATREX's standard, a built-in differential pressure airflow switch described on page 15, senses static pressure in the duct as an indicator of airflow. Separate wiring to the fan motor or its controls is unnecessary.

Alternative methods for detecting airflow include:

1. The fan relay, described on page 15, provides a positive electrical interlock with the fan circuit.
2. A separate contactor, built into the duct heater, can energize the fan when the duct heater is on.
3. A terminal block to allow field connection of external contacts that close the circuit only when the fan is operating.

**Contactors** – Contactors connected to the primary thermal cutout and airflow interlock safety circuits must be provided by the duct heater manufacturer. Effective June 2009 UL requires that all open coil element duct heaters be furnished with disconnecting type controlling, safety and backup contactors breaking all ungrounded

conductors. Practically speaking, this means that all, but small 120 and 277 volt single-phase open coil heaters, must be supplied with either disconnecting contactors built into the heater terminal box or into a remote panelboard. HEATREX's standard is to supply disconnecting contactors which break all ungrounded conductors in open coil heaters. Due to the intrinsic safety of finned tubular duct heaters, UL does not require the use of disconnecting type contactors. HEATREX's standard is to supply de-energizing contactors, which break only one line of single-phase circuits and two lines of three-phase circuits. Disconnecting contactors are available with finned tubular heaters if required.

**Overcurrent Protection** – For heaters drawing more than 48 amps, the duct heater manufacturer must provide some means of overcurrent protection either built into the terminal box or a remote panelboard. While fuses or circuit breakers are available to meet this requirement, HEATREX's standard is fuses.

**Disconnecting Means** – All duct heater installations require a disconnecting means at or within sight of the heater controls. We recommend that a built-in, snap-acting, door interlocking disconnect switch with marked "on" and "off" positions be specified on all duct heaters. This insures the ultimate in safety, since the heater and built-in controls cannot be serviced without turning the disconnect switch off. It is also far less expensive than one obtained and installed in the field.

## International Requirements

HEATREX heaters can be supplied to operate from any electrical system throughout the world. Single and three-phase voltages through 600 volts are available. As described on pages 24 through 31, all type HUA and HUP standard heaters are available in 380, 400 or 415 volt, three-phase ratings. All HEATREX heaters will operate on either 50 or 60 Hz.

† Although UL requirements are uniform throughout the country, local electrical codes may deviate from the NEC. For information on local requirements, consult your HEATREX representative.

